

REVISION RECORD			
REV.	DESCRIPTION	DATE	APPROVED
--	INITIAL RELEASE TKT 22679	15AUG2025	RPM/DRG

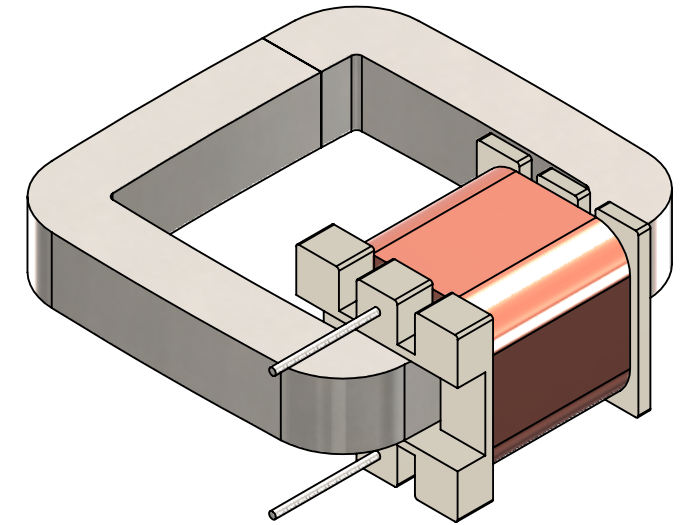
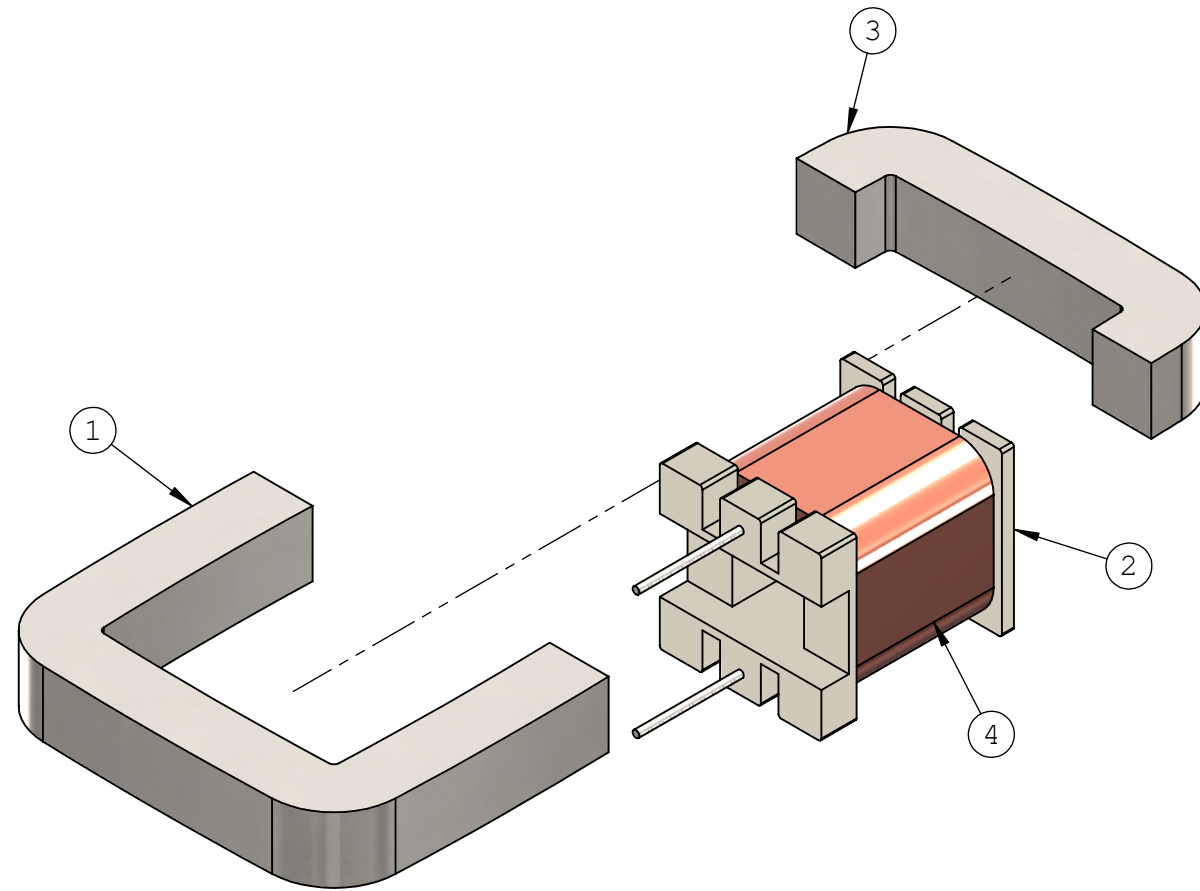

NOTES:

- 1) CORE MATERIAL: M4 GRADE SILICON STEEL
- 2) FREQUENCY: 50/60Hz
- 3) NUMBER OF TURNS: 6000
- 4) WIRE SIZE (DIAMETER): 0.07mm (41 AWG)

ITEM NO.	PART NUMBER	QTY.
1	Current Transformer - Core - Fixed Side	1
2	Current Transformer - Bobbin	1
3	Current Transformer - Core - Moving Side	1
4	Current Transformer - Winding	1

UNLESS OTHERWISE SPECIFIED ALL DIMENSIONS ARE IN INCHES. DIMENSIONS IN BRACKETS ( ) ARE IN MILLIMETERS. TOLERANCES ARE AS FOLLOWS UNLESS OTHERWISE SPECIFIED:	TITLE	INITIALS	DATE	DESCRIPTION:
	CAD	RPM	15AUG2025	
	ENG	JPT	15AUG2025	
	BOM	ADL	15AUG2025	
INCHES .X = ±.06 .XX = ±.030 .XXX = ±.010 ANGULAR = ±1°	MILLIMETERS X=±1.5 X.X=±0.76 X.XX=±0.25	PROJECT# XXXXX	THIRD ANGLE PROJECTION	DWG. SIZE B
				SCALE: 2:1
				SHEET 1 OF 4
				PRODUCT ID BSIZE-EPDM
				REV. --

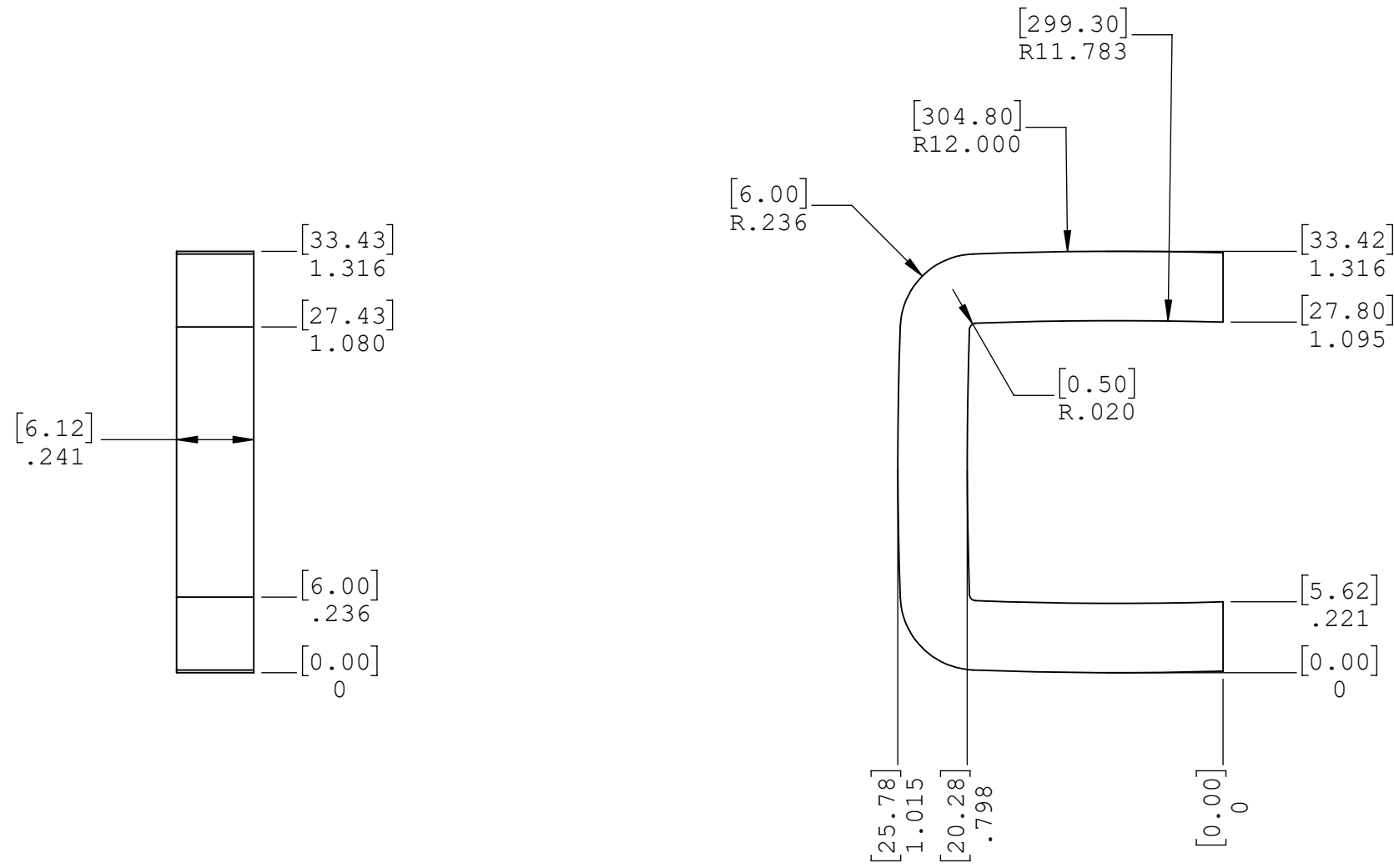
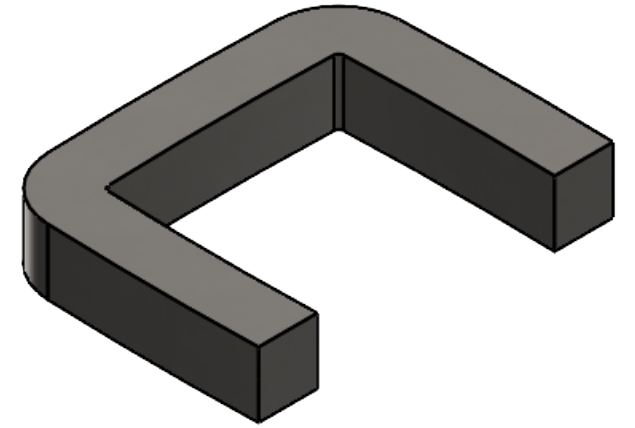

ITEM NO.	PART NUMBER	QTY.
1	Current Transformer - Core - Fixed Side	1

DESCRIPTION:

DWG. SIZE	SCALE	SHEET	PRODUCT ID	REV.
B	2:1	2 OF 4	BSIZE-EPDM	--

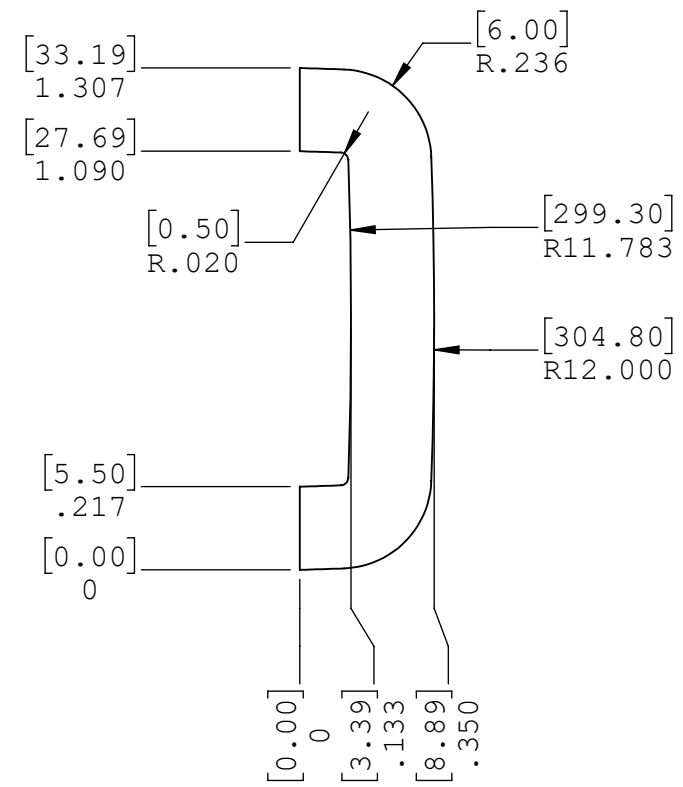
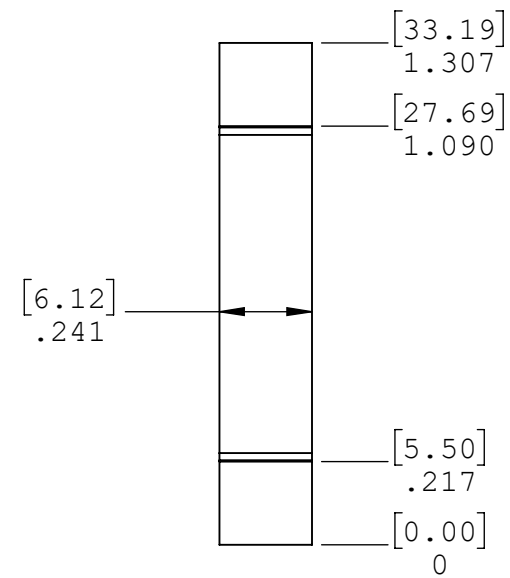
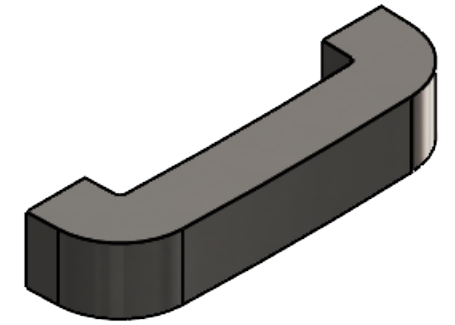

ITEM NO.	PART NUMBER	QTY.
3	Current Transformer - Core - Moving Side	1

DESCRIPTION:

DWG. SIZE B	SCALE: 2:1	SHEET 3 OF 4	PRODUCT ID BSIZE-EPDM	REV. --
----------------	---------------	-----------------	--------------------------	------------

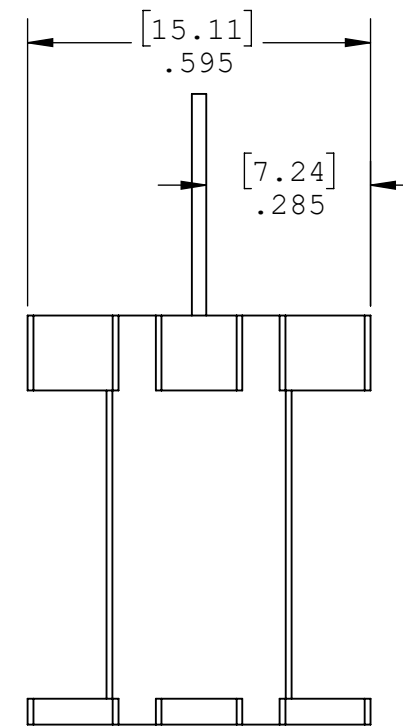
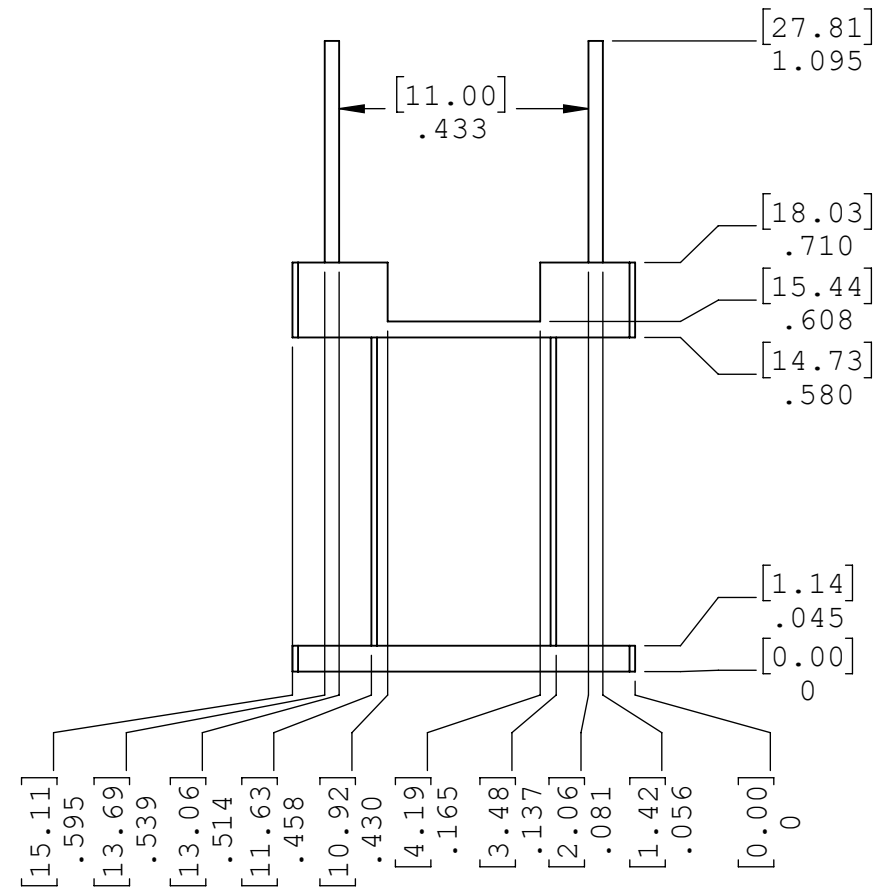
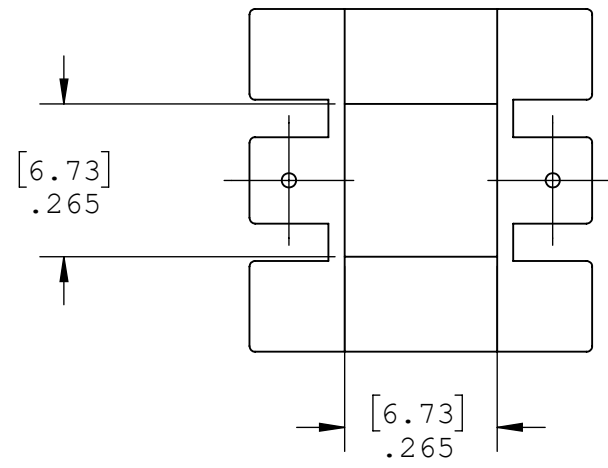
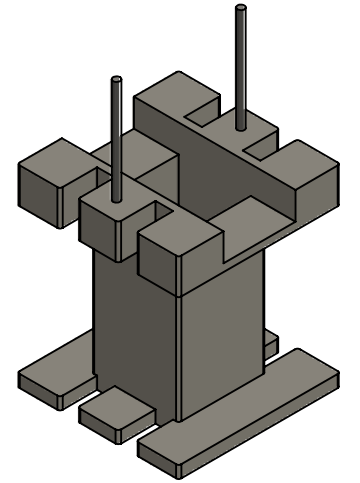

ITEM NO.	PART NUMBER	QTY.
2	Current Transformer - Bobbin	1

DESCRIPTION:

DWG. SIZE B	SCALE 2:1	SHEET 4 OF 4	PRODUCT ID BSIZE-EPDM	REV. --
----------------	--------------	-----------------	--------------------------	------------